

# EBS-15 Specifications

Electron Beam Deflection:	270°
Power Rating:	15kW
Maximum High Voltage:	10kV
High Voltage Range:	6kV to 10kV
Lateral Coil Resistance:	3.0 Ohm
Sweep, Lateral Coil:	+/- 1 Amp
Longitudinal Coil Resistance:	9.5 Ohm
Sweep Longitudinal Coil:	+/- 1 Amp
Emission Current:	up to 1.5Amp@10kV
Filament Power:	600 Watts Maximum
Water Requirements:	3 gpm @ 10kW Impute water temperature should be 60° F (15° C) @ 60 psi (4.2 kg/cm) with 3/8" (10mm) lines.
Weight:	20 lbs. ( 9 kg) As delivered, less shipping carton
Dimensions:	2.910"H x 4.800"W x 10.850"L 7.4 cm H x 12.2 cm W x 27.6 cm L
Maximum Crucible Volume:	100cc

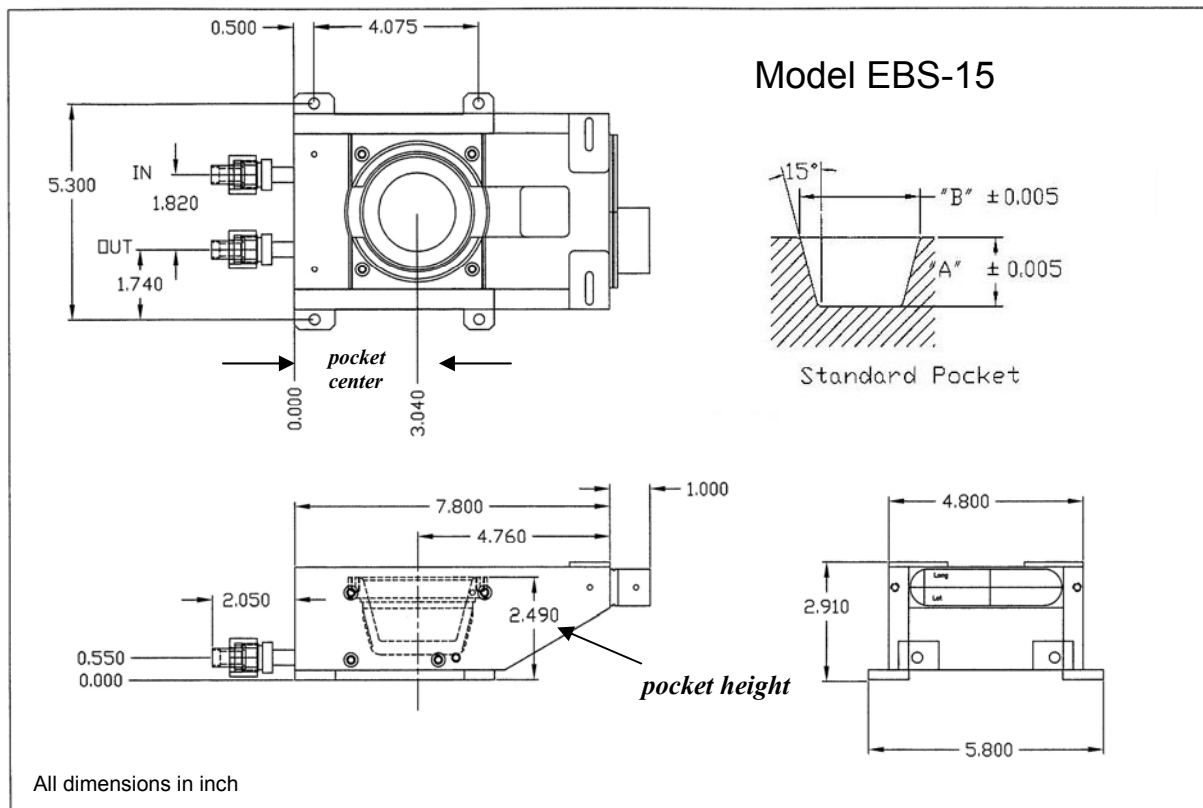

## Crucible Dimensions

Size	"A"	"B"	Part Number#
7cc	.500	1.125	EBS-15-007
15cc	.670	1.485	EBS-15-015
25cc	.680	1.855	EBS-15-025
30cc	.790	1.920	EBS-15-030
40cc	1.020	2.030	EBS-15-040
60cc	1.020	2.410	EBS-15-060
100cc	1.470	2.700	EBS-15-100